

PRIMUS 400: The Premium Model ★★★

Bread slicing has never been so hygienic, so quiet, so fast: PRIMUS 400

Slice at a premium level with PRIMUS 400 and enjoy the **unique advantages of the new Premium-Hygiene-Design**. The open design sets completely new standards. **Slicing bread has never been this hygienic.**

Excellent slicing results for all sorts of bread (even fresh from the oven) in proven TREIF quality, **always a soft sound** and a tremendous slicing speed including the choice between **two slicing speeds** – PRIMUS 400 offers that and more.



With proven TREIF quality, PRIMUS 400 slices all sorts of bread (infeed length: **400 mm/ 15 7/8"**), from soft sandwich bread to double-baked bread with a hard crust (even fresh from the oven) – consistently without blade lubrication.



The faster slicing speed means you can be back with your customers sooner. PRIMUS 400 features two speeds as a standard (130 or 220 slices/minute). Simply select the desired speed with the press of a button.



If required, PRIMUS 400 cuts the bread in half or slices only half of the loaf. The automatic slice holder supports the slices during the cutting process, facilitating removal of the sliced bread.



PRIMUS 400 even produces clean slices on marble cake with chocolate glaze. Of course the machine is also suitable for madeira cake, stollen and raisin loaf.



The open design is unique. Simply open the machine door and detach the removal chute for quick and easy cleaning. This design completely redefines hygiene.



Premium quality – from slicing to cleaning

The **Premium-Hygiene-Design** features a unique open design. Even the removal chute can be detached for cleaning. Contaminations in the technical section (e.g. from flour dust) are prevented by the complete separation from the cutting section.

Technical data:

Two slicing speeds can be selected with a button	Standard
Max. slices/minute	130/ 220 (depending on the slicing speed)
Cross section of product (mm/inch)	330 x 150; 13" x 6"
Infeed length (mm/inch)	400; 15 4/5"
Slice thickness (mm/inch)	4-24; 1/5"-1" (adjustable in 0.5 mm/ 1/50" increments)
Housing dimensions (mm/inch)	
Width/Depth/Height	800/700/1,050; 31 1/2"/27 3/5"/41 3/10"
Operating voltage	230 V
Pre-fuse in the supply line	16 A
Connecting load (kW)	0.9
Weight (kg/lb)	215; 474



Of course, the blade with a unique tothing and a special grinding finish is made by TREIF. TREIF is the only manufacturer of bread slicers that manufactures the blades itself.



The blade protection ensures safe cleaning of the machine. The blade protection is included in the delivery.

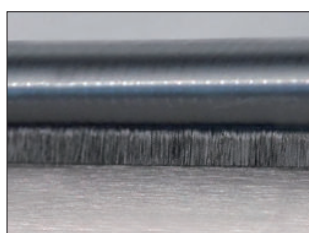

The system of sound-absorbing brushes (a TREIF patent) has proven successful. It was optimised and thoroughly revised for PRIMUS 400. The result: an even softer sound, pleasantly quiet.

nanoblade[®]
TREIF blade manufacturing

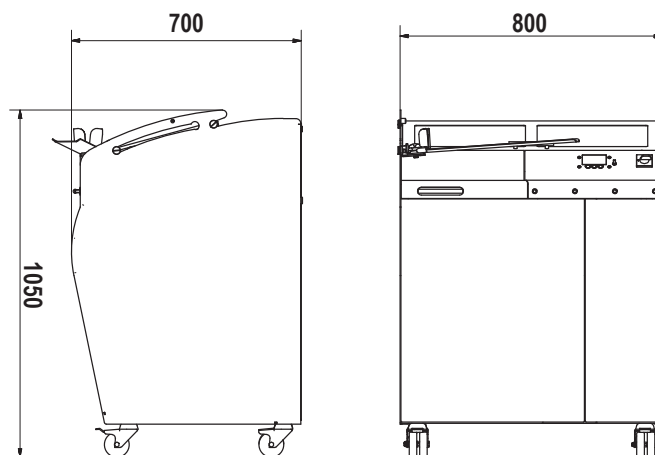

All measurements in mm.

The benefits at a glance:

- **Premium-Hygiene-Design:** open design, detachable removal chute for cleaning, numerous slots for quick sweeping out of crumbs, complete separation of cutting and technical sections
- **Smooth sound:** sound-optimised slicing/ optimisation of the proven system of sound-absorbing brushes (TREIF patent)
- **Two slicing speeds (standard):** up to 220 slices/minute, selectable with a button (standard)
- **Universal bread slicing machine:** Slices all sorts of bread (oven fresh), no blade lubrication
- **One-button operating system** for all functions (setting slice thickness, loaf halving, number of slices and slicing speed)
- **Long-term use of circular blade** thanks to special grinding finish; high quality standard due to own blade manufacturing (*nanoblade*); easy cleaning of the blade without dismantling
- **Simpler handling** thanks to the automatic slice holder
- **Machine delivery includes:** blade protection, a pair of cut-resistant gloves and a blade-changing tool
- Storage for clips for sealing bread bags (optional)

HEADQUARTERS:

Marel TREIF GmbH
Toni-Reifenhüser-Str. 1
D-57641 Oberfähr
Tel. +49 2685 944 0
Fax +49 2685 1025
E-Mail: info@treif.com

LOCATIONS:

TREIF USA Inc.
50 Waterview Drive, Suite 130
USA Shelton CT 06484
Tel. +1 203 929 9930
Fax +1 203 929 9949
E-Mail: treifusa@treif.com

TREIF U.K. Ltd.
Genesis House, Poole Hall Road,
Poole Hall Industrial Estate
Ellesmere Port, GB-Cheshire CH66 1ST
Tel.: +44 (0) 151 3506100
Fax: +44 (0) 151 3506101
E-Mail: treifuk@treif.com

TREIF Italia S.r.l.
Via Sant'Agnesa 43-45
40132 Bologna, Italia
Tel.: +39 051 728138
E-Mail: info.it@treif.com

TREIF S.A.R.L.
22, rue des Tuileries
F - 67460 Souffelweyersheim
Tel.: +33 3 88184018
Fax: +33 3 88184019
E-Mail: info-france@treif.com

TREIF in Belgium
Villalaan 21
B-9320 Raist
Tel.: +32 53 770813
Fax: +32 53 789666
E-Mail: jo.luyckaert@treif.com

TREIF Sp. z o.o.
ul. Jana Kochanowskiego 49
01-864 Warszawa
tel: + 48 506 412 522
service: + 48 506 413 197
E-Mail: infopl@treif.com