

Eazy: The compact entry-model

Slicing bread flexibly, safely and hygienically: The new Eazy

As entry-level model, the new Eazy offers numerous **comfort-functions** with which you can quickly and easily satisfy all customer's requirements in the field of bread slicing. The **safety-concept** reliably protects the operators at any time. Eazy is suitable for all types of bread (infeed-chute length 320 mm). Thanks to its **compact dimensions** its footprint is very small, and on its practical wheels it remains mobile at all times. Additionally, the **Premium-Hygiene-Design** ensures a **fast and efficient cleaning**.



The Eazy offers a complete flexibility with regard to the cutting thickness: It is settable from 4 up to 14 mm. From soft to crunchy - it slices all sorts of bread perfectly and without blade lubrication.



The high-quality operating panel makes the handling of the Eazy-bread slicer particularly easy and clear. As with the large series, you can set the cutting thickness via the rotary switch and start the slicing by pressing the button.

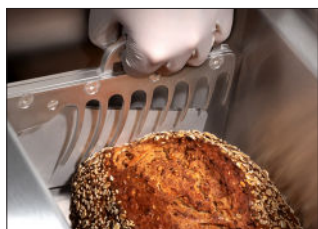

The semi-automatic loaf-halving is especially comfortable. You only have to place the loaf of bread in the middle. Then the Eazy halves the bread and slices the half of the loaf.



The bagging aid allows an easy and fast bagging of the sliced bread.



Modern, top quality and versatile. Thanks to its classic-timeless stainless steel-optics, the Eazy bread slicer fits harmoniously into any salesroom and any corporate design.



The Eazy is equipped with a moveable lid which can be wide opened so that the insertion tray is easily accessible for the cleaning process.



Eazy is simple: Slicing, cleaning, safety

The **Premium-Hygienic-Design** with its open construction simplifies the cleaning and provides an optimum cleanliness when slicing bread. Thanks to its flexible lid and the special blade-cleaning position all places to be cleaned in the bread-removal-area are easily and safely accessible.

Technical data:

Maximum cuts/	130
Infeed chute cross section (mm)	330 x 150
Infeed chute length (mm)	320
Slice thickness (mm)	4-14
Housing dimensions (mm)	
Width / Depth / Height	650 / 700 / 1048,4
Operating voltage	230 V
Pre-fuse in the supply line	16 A
Connection load (kW)	1,3
Weight (kg)	195

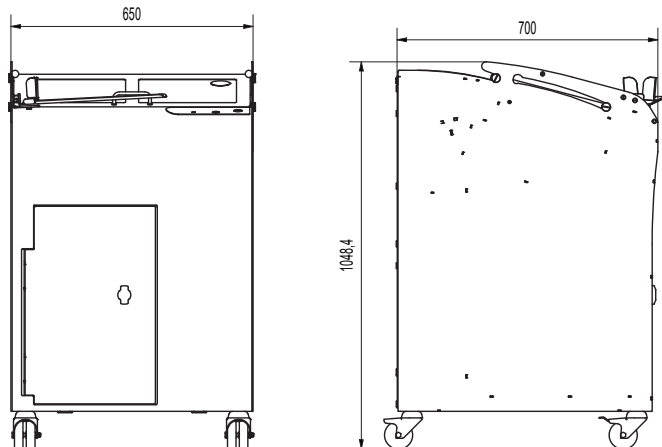

The nanoBlade developed and manufactured by Treif has a special coating and tothing. In combination with the planetary gear, it allows the lubrication-free slicing of fresh breads.

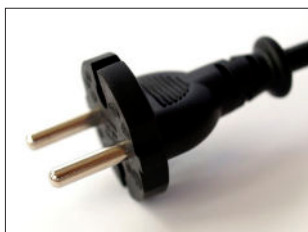

Eazy bread slicers require a supply voltage of 230 Volt. With a Schuko-plug it can be connected quickly and easily anywhere.

The benefits at a glance:

- Multi-purpose bread slicer for all loaf types up to 320 mm length, oven fresh, without blade lubrication; up to 130 slices/minute
- Premium-Hygiene-Design: Amongst others additional slot openings in the bread removal area to brush away the crumbs quickly; crumbs are collected in an easily removable tray; user-friendly cleaning due to flexible lid and blade cleaning position
- Compact design: Small footprint, like grid set slicer
- Variable slice thicknesses, adjustable by rotary knob
- Semi-automatic loaf-halving
- Maximum service life of the circular knife thanks to own knife manufacturing (nanoBlade®), easy blade cleaning without disassembly
- Optional accessories: Bread bag holder, storage for clips for the sealing of the bread bags
- Machine supply with a pair of cut-resistant gloves and a blade changing tool

nanoblade[®]
TREIF Messerfertigung

HEADQUARTERS:
Marel TREIF GmbH
Toni-Reifenhäuser-Str. 1
D-57641 Oberlahr
Phone. +49 2685 944 0
Fax +49 2685 1025
E-Mail: info@treif.com

For further locations, please see our homepage.

www.treif.com