







RANGE
bts

 bernardi®



Complex doughs, made simple.

BTs range represents the top model among all large mixers with wheels. It is the most suitable kneading machine for the preparation of high-hydration doughs and for all large leavened products. Thanks to its compact dimensions and good price-performance ratio, it is the best ally for professionals who want to stand out.

-  **Removable arms**
for easy cleaning
-  **Touch**
control panel
-  **Hole in the safety protection**
for adding ingredients easily
-  **5 speed steps**
30 to 65 strokes/minutes
-  Bluetooth connection
to "MixDrive" app
-  **Available in three sizes**
12, 24 and 48 kg dough
-  **Voltage 400V** three-phase
or 230V single-phase on request



SCAN THE QR CODE
FOR MORE INFORMATION

Technical details

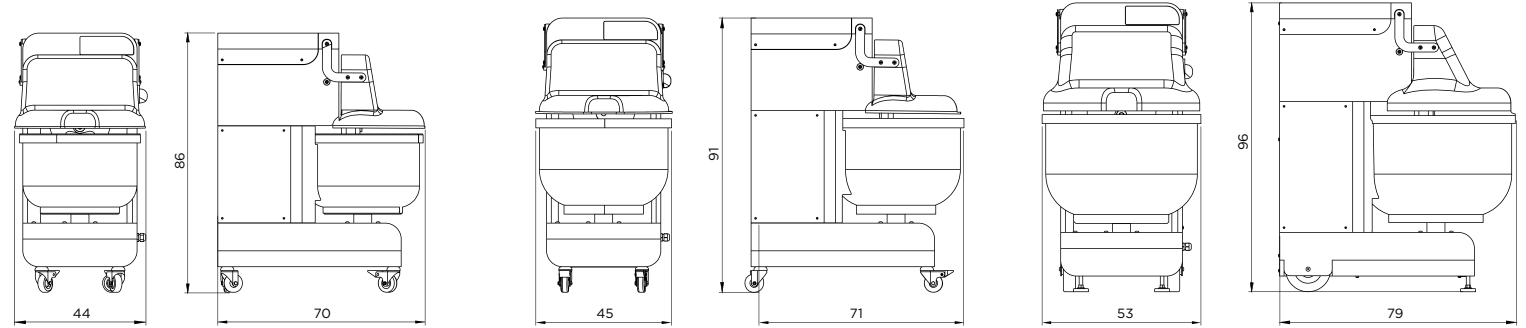

Model

bt 12_sbt 24_sbt 48_s

Flour capacity	1.3 - 8 kg	2 - 15 kg	3 - 30 kg
Dough capacity	2 - 12 kg	3 - 24 kg	5 - 48 kg
Bowl capacity	27 l	35 l	60 l
Bowl size (cm)	ø 38 - h 25	ø 43 - h 30	ø 50 - h 34
Voltage	400V three-phase*	400V three-phase*	400V three-phase*
Power	1100 W	1500 W	1500 W
Speed steps	5 speed steps	5 speed steps	5 speed steps
Strokes (strokes/min)	from 30 to 65	from 30 to 65	from 30 to 65
Dimensions LxWxH (cm)	44x70x86	45x71x91	53x79x96
Weight	128 kg	140 kg	154 kg
Product code	BT1240059	BT2440059	BT4840059
Timer	App MixDrive	App MixDrive	App MixDrive
Packaging dimensions (cm)	55x81x110	55x81x110	63x89x116
Packaging weight	150 kg	165 kg	200 kg

*Customisation on request: 230V single-phase