



PROFESSIONAL CATALOGUE

September 2016

PROFESSIONAL OVENS

NO COMPROMISE IN COOKING PERFORMANCE

All Smeg Foodservice ovens are designed to maintain an extremely stable and uniform temperature inside the cavity, ensuring perfect cooking results, every time.

STRENGTH

Smeg catering products draw on the experience of over 30 years in the Foodservice industry. The ovens are built with the highest-quality materials, making them particularly tough and strong.

SAFETY

Specific materials and sophisticated design features allow optimum use of Smeg ovens with absolute confidence in their safety. The use of the highest-quality materials ensures cleanliness and hygiene, satisfying the most rigid requirements.

SOPHISTICATED DESIGN

Smeg ovens are immediately recognisable by their fine design. Attractive to look at, they are suitable for installation in prominent positions, and are ideally suited for front-of-house. They are spacious, easy to use and simple to install; the ideal working tool for all foodservice environments.

FAN SYSTEM

The heat in the ovens is distributed by means of one, two or three fans. When two or three fans are present, they are turning in opposite directions, with timed direction reversal; this alternating operation guarantees uniform cooking and enhances the browning of food products in all larger cavities.

POWER CONSUMPTION

Power consumption in the Smeg Foodservice ovens varies between 3.0 and 16 kW, according to model and power setting.

VERSATILITY

The complete Smeg Foodservice catalogue offers a range of ovens for all needs and environments, fulfilling any requirement in the most efficient and high-performing way.

GRILL FUNCTION

Three models are equipped with a grill function, used to give food a mouth-watering golden colour after cooking.

WARM-UP, TEMPERATURE RECOVERY, TEMPERATURE MAINTENANCE

Operating temperature is reached through a rapid initial preheating phase. Even when cooking/reheating food from frozen, Smeg Foodservice ovens are capable of reacting to the substantial and temporary drop in temperature, recovering the initial temperature within just a few minutes. The temperature inside the oven will then be very accurately maintained, with variations of only a few degrees, even at the highest temperatures.

HUMIDIFICATION SYSTEM

In humidified oven models, the fan system is combined with a humidification system. Water injected onto the fan from a direct connection to the water supply is nebulised and passed through the heating element, transforming it into steam.

PROFESSIONAL OVENS

Convection oven

ALFA43 — 4 trays 435x320mm

- ◇ Compact and functional design, robust construction
- ◇ Manual electromechanical controls, extremely simple and reliable
- ◇ Excellent baking uniformity across all trays, perfect heat distribution in all conditions of use
- ◇ Excellent internal visibility, due to the large glass and powerful inner light
- ◇ Double glass door, with internal glass removable for cleaning
- ◇ Flexible use for many different types of cooking
- ◇ 4 flat aluminium trays (model 3820) included
- ◇ 15A plug



| ALFA43 | |
|--------------------------------------|----------------------|
| trays capacity and dimensions (mm) | 4 trays 435x320 |
| distance between trays (mm) | 80 |
| temperature range | 50–250°C |
| timer | 1–60min + manual |
| power rating & electrical connection | 3 kW, 230V 1N – 50Hz |
| dimensions WxDxH (mm) | 602x584x537 |

PROFESSIONAL OVENS

Humidified convection oven with grill

ALFA43GH — 4 trays 435x320mm

- ◇ Compact and functional design, robust construction
- ◇ Manual electromechanical controls, extremely simple and reliable
- ◇ Excellent baking uniformity across all trays, perfect heat distribution in all conditions of use
- ◇ Excellent internal visibility, thanks to the large glass and powerful inner light
- ◇ Double glass door, with internal glass removable for cleaning
- ◇ Flexible use for many different types of cooking
- ◇ Manual humidifier, through a plumbed water system connection, for excellent results with all types of food
- ◇ Manual grill function
- ◇ 2 flat aluminium trays (model 3820) and 2 flat chrome grids (model 3729) included
- ◇ 15A plug



| ALFA43GH | |
|--------------------------------------|----------------------|
| trays capacity and dimensions (mm) | 4 trays 435x320 |
| distance between trays (mm) | 80 |
| temperature range | 50–250°C |
| timer | 1–60min + manual |
| power rating & electrical connection | 3 kW, 230V 1N – 50Hz |
| dimensions WxDxH (mm) | 602x584x537 |

PROFESSIONAL OVENS

Electronic convection oven

ALFA43XE — 4 trays 435x320mm

- ◇ Compact and functional design, robust construction
- ◇ Electronic controls, extremely precise, simple and reliable
- ◇ Memory storage capacity for 40 programs with pre-heating function
- ◇ Excellent baking uniformity across all trays, perfect heat distribution in all conditions of use
- ◇ Excellent internal visibility, due to the large glass and powerful inner light
- ◇ Double glass door, with internal glass removable for cleaning
- ◇ Flexible use for many different types of cooking
- ◇ 4 flat aluminium trays (model 3820) included
- ◇ 15A plug



| ALFA43XE | |
|--------------------------------------|----------------------|
| trays capacity and dimensions (mm) | 4 trays 435x320 |
| distance between trays (mm) | 80 |
| temperature range | 50–280°C |
| timer | 1–99min + manual |
| power rating & electrical connection | 3 kW, 230V 1N – 50Hz |
| dimensions WxDxH (mm) | 602x584x537 |

PROFESSIONAL OVENS

Humidified electronic convection oven

ALFA43XEHPL — 4 trays 435x320mm

- ◇ Compact and functional design, robust construction
- ◇ Electronic controls, extremely precise, simple and reliable
- ◇ Memory storage capacity for 40 programs with pre-heating function
- ◇ Excellent baking uniformity across all trays, perfect heat distribution in all conditions of use
- ◇ Excellent internal visibility, due to the large glass and powerful inner light
- ◇ Double glass door, with internal glass removable for cleaning
- ◇ Flexible use for many different types of cooking
- ◇ Three-level automatic humidifier (can also be adjusted manually) through a plumbed water system connection, for excellent results with all types of food
- ◇ 4 flat aluminium trays (model 3755) included
- ◇ 15A plug



| ALFA43XEHPL | |
|--------------------------------------|----------------------|
| trays capacity and dimensions (mm) | 4 trays 435x320 |
| distance between trays (mm) | 80 |
| temperature range | 50–280°C |
| timer | 1–99min + manual |
| power rating & electrical connection | 3 kW, 230V 1N – 50Hz |
| dimensions WxDxH (mm) | 602x584x537 |

PROFESSIONAL OVENS

Convection oven

ALFA140 — 4 trays GN1/1* (or 600x400mm optional)

- ◇ Compact and functional design, robust stainless steel construction
- ◇ Full stainless steel oven cavity
- ◇ Manual electromechanical controls, extremely simple and reliable
- ◇ Rack suitable for GN1/1* trays (or 600x400mm optional)
- ◇ Consistent baking uniformity across all trays, due to one bidirectional fan with timed rotation reversal
- ◇ Excellent internal visibility due to the large glass and powerful inner light
- ◇ Double glass door, with internal glass removable for cleaning
- ◇ 15A plug



| ALFA140 | |
|--------------------------------------|---|
| trays capacity and dimensions (mm) | 4 trays GN1/1* (or 600x400mm optional) |
| distance between trays (mm) | 77 |
| temperature range | 50–250°C |
| timer | 1–60min + manual |
| power rating & electrical connection | 3 kW, 230V 1N – 50Hz |
| dimensions WxDxH (mm) | 780x715x562 |

* GN1/1 with minimum 20mm depth

PROFESSIONAL OVENS

Convection oven

ALFA145 — 4 trays 600x400mm or GN1/1*

- ◇ Compact and functional design, robust stainless steel construction
- ◇ Full stainless steel oven cavity
- ◇ Side opening door with left hand hinges
- ◇ Manual electromechanical controls, extremely simple and reliable
- ◇ Rack suitable both for 600x400 and GN1/1* trays
- ◇ Excellent baking uniformity across all trays, due to two fans rotating in opposite directions and with timed rotation reversal. This ensures a perfect heat distribution in all conditions of use
- ◇ Excellent internal visibility due to the large glass and powerful inner light
- ◇ Double glass door, with internal glass removable for cleaning
- ◇ Flexible use for many different types of cooking
- ◇ "FAST" push button to raise power to 6.7 kW thus reducing pre-heating and cooking time



| ALFA145 | |
|--------------------------------------|--|
| trays capacity and dimensions (mm) | 4 trays 600x400 or GN1/1* |
| distance between trays (mm) | 77 |
| temperature range | 50–250°C |
| timer | 1–60min + manual |
| power rating & electrical connection | 6.7 kW, 230V 1N – 50Hz 6.7 kW, 400V 3N – 50Hz |
| dimensions WxDxH (mm) | 780x715x562 |

* GN1/1 with minimum 20mm depth

PROFESSIONAL OVENS

Convection oven

ALFA143XM — 4 trays 600x400mm or GN1/1*

- ◇ Compact and functional design, robust stainless steel construction
- ◇ Full stainless steel oven cavity
- ◇ Manual electromechanical controls, extremely simple and reliable
- ◇ Rack suitable both for 600x400 and GN1/1* trays
- ◇ Excellent baking uniformity across all trays, due to two fans rotating in opposite directions and with timed rotation reversal. This ensures a perfect heat distribution in all conditions of use
- ◇ Excellent internal visibility due to the large glass and powerful inner light
- ◇ Double glass door, with internal glass removable for cleaning
- ◇ Flexible use for many different types of cooking
- ◇ "FAST" push button to raise power to 6.7 kW thus reducing pre-heating and cooking time



| ALFA143XM | |
|--------------------------------------|--|
| trays capacity and dimensions (mm) | 4 trays 600x400 or GN1/1* |
| distance between trays (mm) | 77 |
| temperature range | 50–250°C |
| timer | 1–60min + manual |
| power rating & electrical connection | 6.7 kW, 230V 1N – 50Hz 6.7 kW, 400V 3N – 50Hz |
| dimensions WxDxH (mm) | 780x715x562 |

* GN1/1 with minimum 20mm depth

PROFESSIONAL OVENS

Electronic convection oven

ALFA144XE — 4 trays 600x400mm or GN1/1*

- ◇ Compact and functional design, robust stainless steel construction
- ◇ Full stainless steel oven cavity
- ◇ Electronic controls, extremely precise, simple and reliable
- ◇ Memory storage capacity for 40 programs with pre-heating function
- ◇ Power adjustable at 3.0 or 5.5 or 8.3 kW (8.3 kW only 400V 3N – 50Hz)
- ◇ Rack suitable both for 600x400 and GN1/1* trays
- ◇ Excellent baking uniformity across all trays, due to two fans rotating in opposite directions and with timed rotation reversal. This ensures a perfect heat distribution in all conditions of use
- ◇ Excellent internal visibility due to the large glass and powerful inner light
- ◇ Double glass door, with internal glass removable for cleaning
- ◇ Flexible use for many different types of cooking
- ◇ Rapid cooling cycle



| ALFA144XE | |
|--------------------------------------|--|
| trays capacity and dimensions (mm) | 4 trays 600x400 or GN1/1* |
| distance between trays (mm) | 77 |
| temperature range | 50–280°C |
| timer | 1–99min + manual |
| power rating & electrical connection | 5.7 kW, 230V 1N – 50Hz 8.4 kW, 400V 3N – 50Hz |
| dimensions WxDxH (mm) | 780x715x562 |

* GN1/1 with minimum 20mm depth

PROFESSIONAL OVENS

Humidified convection oven with grill

ALFA143GH — 4 trays 600x400mm or GN1/1*

- ◇ Compact and functional design, robust stainless steel construction
- ◇ Full stainless steel oven cavity
- ◇ Manual electromechanical controls, extremely simple and reliable
- ◇ Rack suitable both for 600x400 and GN1/1* trays
- ◇ Excellent baking uniformity across all trays, due to two fans rotating in opposite directions and with timed rotation reversal. This ensures a perfect heat distribution in all conditions of use
- ◇ Excellent internal visibility due to the large glass and powerful inner light
- ◇ Double glass door, with internal glass removable for cleaning
- ◇ Flexible use for many different types of cooking
- ◇ Manual humidifier, through a plumbed water system connection, for excellent results with all types of food
- ◇ Manual grill function
- ◇ "FAST" push button to raise power to 6.7 kW thus reducing pre-heating and cooking time



| ALFA143GH | |
|--------------------------------------|--|
| trays capacity and dimensions (mm) | 4 trays 600x400 or GN1/1* |
| distance between trays (mm) | 77 |
| temperature range | 50–250°C |
| timer | 1–60min + manual |
| power rating & electrical connection | 6.7 kW, 230V 1N – 50Hz 6.7 kW, 400V 3N – 50Hz |
| dimensions WxDxH (mm) | 780x715x562 |

* GN1/1 with minimum 20mm depth

PROFESSIONAL OVENS

Humidified electronic convection oven with grill

ALFA144GH — 4 trays 600x400mm or GN1/1*

- ◇ Compact and functional design, robust stainless steel construction
- ◇ Full stainless steel oven cavity
- ◇ Electronic controls, extremely precise, simple and reliable
- ◇ Memory storage capacity for 40 programs with pre-heating function
- ◇ Power adjustable at 3.0 or 5.5 or 8.3 kW (8.3 kW only 400V 3N – 50Hz)
- ◇ Rack suitable both for 600x400 and GN1/1* trays
- ◇ Excellent baking uniformity across all trays, due to two fans rotating in opposite directions and with timed rotation reversal. This ensures a perfect heat distribution in all conditions of use
- ◇ Excellent internal visibility due to the large glass and powerful inner light
- ◇ Double glass door, with internal glass removable for cleaning
- ◇ Flexible use for many different types of cooking
- ◇ Rapid cooling cycle
- ◇ Three-level automatic humidifier (can also be adjusted manually) through a plumbed water system connection, for excellent results with all types of food
- ◇ Programmable grill function at the end of cooking cycle



| ALFA144GH | |
|--------------------------------------|--|
| trays capacity and dimensions (mm) | 4 trays 600x400 or GN1/1* |
| distance between trays (mm) | 77 |
| temperature range | 50–280°C |
| timer | 1–99min + manual |
| power rating & electrical connection | 5.7 kW, 230V 1N – 50Hz 8.4 kW, 400V 3N – 50Hz |
| dimensions WxDxH (mm) | 780x715x562 |

* GN1/1 with minimum 20mm depth

PROFESSIONAL OVENS

Humidified convection oven

ALFA241XM — 6 trays 600x400mm or GN1/1*

- ◇ Robust stainless steel construction, modern and functional design
- ◇ Full stainless steel oven cavity
- ◇ Adjustable rack, suitable both for 600x400 and GN1/1* trays
- ◇ Electromechanical controls, extremely simple and reliable
- ◇ Excellent baking uniformity across all trays, due to two fans rotating in opposite directions and with timed rotation reversal. This ensures a perfect heat distribution in all conditions of use
- ◇ Excellent internal visibility, due to the large glass and powerful inner light
- ◇ Triple glass door, all can be opened for cleaning. Reduces heat dispersion and energy consumption decreases by almost 15%
- ◇ Double-stage door opening system
- ◇ Rapid cooling cycle
- ◇ Flexible use for many different types of cooking
- ◇ Manual humidifier, through a plumbed water system connection, with water injection on each fan, for excellent results with all types of food



| ALFA241XM | |
|--------------------------------------|---------------------------|
| trays capacity and dimensions (mm) | 6 trays 600x400 or GN1/1* |
| distance between trays (mm) | 80 |
| temperature range | 50–250°C |
| timer | 1–60min + manual |
| power rating & electrical connection | 8.5 kW, 400V 3N – 50Hz |
| dimensions WxDxH (mm) | 872x810x805 |

* GN1/1 with minimum 20mm depth

PROFESSIONAL OVENS

Humidified electronic convection oven

ALFA241VE — 6 trays 600x400mm or GN1/1*

- ◇ Robust stainless steel construction, modern and functional design
- ◇ Full stainless steel oven cavity
- ◇ Adjustable rack, suitable both for 600x400 and GN1/1* trays
- ◇ Electronic controls, extremely precise, simple and reliable
- ◇ Power adjustable at 5.5 or 8.3 kW
- ◇ Memory storage capacity for 40 programs with pre-heating
- ◇ Excellent baking uniformity across all trays due to two fans rotating in opposite directions and with timed rotation reversal. This ensures a perfect heat distribution in all conditions of use
- ◇ Excellent internal visibility, due to the large glass and powerful inner light
- ◇ Triple glass door, all can be opened for cleaning. Reduces heat dispersion and energy consumption decreases by almost 15%
- ◇ Double-stage door opening system
- ◇ Rapid cooling cycle
- ◇ Flexible use for many different types of cooking
- ◇ Rapid cooling cycle
- ◇ Three-level automatic humidifier and with water injection on each fan (can also be adjusted manually), through a plumbed water system connection, for excellent results with all types of food



| ALFA241VE | |
|--------------------------------------|---------------------------|
| trays capacity and dimensions (mm) | 6 trays 600x400 or GN1/1* |
| distance between trays (mm) | 80 |
| temperature range | 50–280°C |
| timer | 1–99min + manual |
| power rating & electrical connection | 8.5 kW, 400V 3N – 50 Hz |
| dimensions WxDxH (mm) | 872x810x805 |

* GN1/1 with minimum 20mm depth

PROFESSIONAL OVENS

Humidified convection oven

ALFA341XM — 10 trays 600x400mm or GN1/1*

- ◇ Robust stainless steel construction, modern and functional design
- ◇ Full stainless steel oven cavity
- ◇ Adjustable rack, suitable both for 600x400 and GN1/1* trays
- ◇ Electromechanical controls, extremely simple and reliable
- ◇ Excellent baking uniformity across all trays due to three fans rotating in opposite directions and with timed rotation reversal. This ensures a perfect heat distribution in all conditions of use
- ◇ Excellent internal visibility, due to the large glass and powerful inner light
- ◇ Triple glass door, all can be opened for cleaning. Reduces heat dispersion and energy consumption decreases by almost 15%
- ◇ Double-stage door opening system
- ◇ Rapid cooling cycle
- ◇ Flexible use for many different types of cooking
- ◇ Manual humidifier, through a plumbed water system connection, with water injection on each fan, for excellent results with all types of food



| ALFA341XM | |
|--------------------------------------|----------------------------|
| trays capacity and dimensions (mm) | 10 trays 600x400 or GN1/1* |
| distance between trays (mm) | 80 |
| temperature range | 50–250°C |
| timer | 1–60min + manual |
| power rating & electrical connection | 16.2 kW, 400V 3N – 50 Hz |
| dimensions WxDxH (mm) | 872x810x1125 |

* GN1/1 with minimum 20mm depth

PROFESSIONAL OVENS

Humidified electronic convection oven

ALFA341VE — 10 trays 600x400mm or GN1/1*

- ◇ Robust stainless steel construction, modern and functional design
- ◇ Full stainless steel oven cavity
- ◇ Adjustable rack, suitable both for 600x400 and GN1/1* trays
- ◇ Electronic controls, extremely precise, simple and reliable
- ◇ Power adjustable at 9 or 15 kW
- ◇ Memory storage capacity for 40 programs with pre-heating function
- ◇ Excellent baking uniformity across all trays due to three fans rotating in opposite directions and with timed rotation reversal. This ensures a perfect heat distribution in all conditions of use
- ◇ Excellent internal visibility, due to the large glass and powerful inner light
- ◇ Triple glass door, all can be opened for cleaning. Reduces heat dispersion and energy consumption decreases by almost 15%
- ◇ Double-stage door opening system
- ◇ Rapid cooling cycle
- ◇ Flexible use for many different types of cooking
- ◇ Rapid cooling cycle
- ◇ Three-level automatic humidifier and with water injection on each fan (can also be adjusted manually), through a plumbed water system connection, for excellent results with all types of food



| ALFA341VE | |
|--------------------------------------|----------------------------|
| trays capacity and dimensions (mm) | 10 trays 600x400 or GN1/1* |
| distance between trays (mm) | 80 |
| temperature range | 50–280°C |
| timer | 1–99min + manual |
| power rating & electrical connection | 16.2 kW, 400V 3N – 50 Hz |
| dimensions WxDxH (mm) | 872x810x1125 |

* GN1/1 with minimum 20mm depth

PROFESSIONAL OVEN STANDS

TVL40 – oven stand



- ◇ stainless steel
- ◇ suitable for ALFA43 series (one oven load)
- ◇ distance between trays: 70mm
- ◇ 600mmW x 600mmD x 900–950mmH
- ◇ adjustable feet
- ◇ 8 tray capacity (435 x 320mm)

TVL140 – oven stand



- ◇ stainless steel
- ◇ suitable for ALFA143, ALFA144 series (one oven load)
- ◇ distance between trays: 70mm
- ◇ 780mmW x 700mmD x 900–950mmH
- ◇ adjustable feet
- ◇ 8 tray capacity (600x400mm or GN1/1)

TVL140D – oven stand

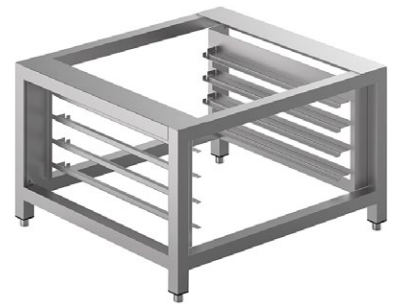

- ◇ stainless steel
- ◇ suitable for ALFA143, ALFA144 series (two oven load)
- ◇ Distance between trays: 70mm
- ◇ 780mmW x 700mmD x 504mmH
- ◇ adjustable feet
- ◇ 4 tray capacity (600x400mm or GN1/1)

TVL240 – oven stand



- ◇ stainless steel
- ◇ suitable for ALFA241 series (one oven load)
- ◇ distance between trays: 70mm
- ◇ 900mmW x 850mmD x 900–950mmH
- ◇ adjustable feet
- ◇ 16 tray capacity (600x400mm or GN1/1)

TVL340 – oven stand



- ◇ stainless steel
- ◇ suitable for ALFA341 series (one oven load)
- ◇ distance between trays: 70mm
- ◇ 900mmW x 850mmD x 616mmH
- ◇ adjustable feet
- ◇ 8 tray capacity (600x400mm or GN1/1)

Stand upper and lower shelves*

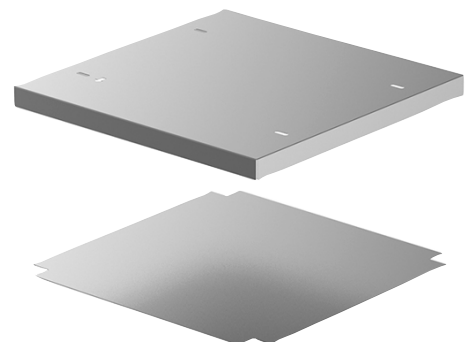

- 2RIP40* – for TVL40
- 2RIP140* – for TVL140 & TVL140D
- 2RIP240* – for TVL240 & TVL340

*stainless steel

PROFESSIONAL OVEN ACCESSORIES

435x320mm trays/grids



3820 — aluminised steel tray

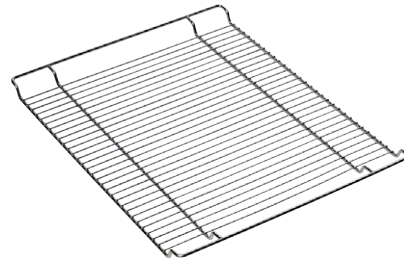

3729 — chrome grid



3780 — non-stick tray

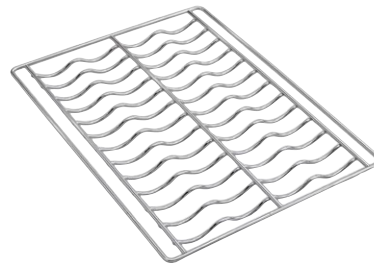

3735 — undulated chrome grid



3755 — flat aluminium tray with holes

600x400mm trays/grids



3743 — flat aluminium tray

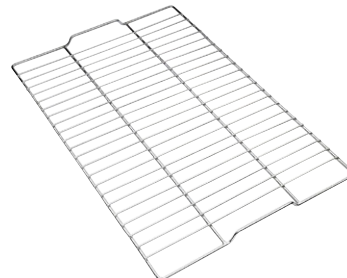

3805 — chrome grid

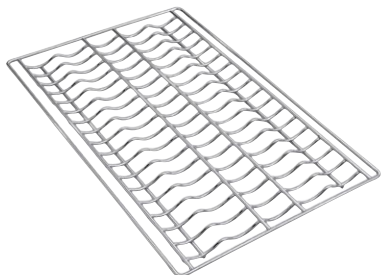

3810 — undulated chrome grid



3751 — flat aluminium tray with holes



Smeg Australia Pty Ltd, 2 Baker Street, Banksmeadow 2019, 02 8667 4888
www.smegfoodservice.com | info@smeg.com.au